

BLM-BT04-E



BLM World Limited

BLM-BT04-E Datasheet

Content

1、 Overview	3
2、 Module default parameters	3
3、 Application area:	4
4、 Power consumption parameters:	5
5、 RF characteristics	5
6、 transparent transmission parameters	5
7、 Module pin description and minimum circuit diagram	6
8、 Pin function description:	6
9、 Other configuration.....	7
11、 LAYOUT considerations	7
12、 AT COMMAND	8
12.1 、 Test Command:	10
12.2 、 Software restart:	10
12.3 、 Get The Software Version:	10
12.4 、 Restore default settings:	10
12.7 、 Set/Query-Pairing password:	11
12.8 、 Set/Query - Serial Port Baud Rate:	11
13、 Contact us	14

1、 Overview

BLM-BT04-E Bluetooth module is specially built for intelligent wireless data transmission by BLM World Limited. SPP+BLE dual-mode Bluetooth.

This module supports the UART interface and the SPP Bluetooth serial protocol. It has the advantages of low cost, small size, low power consumption, and high sensitivity of receiving and sending. It only needs to be equipped with a few peripheral components to achieve its powerful functions.

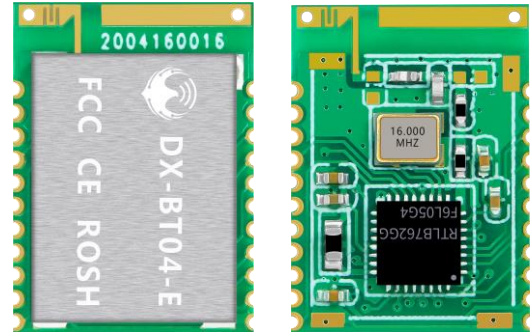

2、 Module default parameters

Bluetooth Protocol	Bluetooth Specification V3.0 SPP +V4.2 BLE
Working Frequency	2.4GHz ISM band
Communication Interface	UART
PowerSupply	MIN:1.8V –MAX:3.6V (Suggest 3.3V)
antenna	PCB onboard antenna
Communication distance	30-40M (Open and unobstructed environment)
Physical Dimension	16.1mm x 11.4mm x 2 mm
Physical Dimension	ROHS REACH FCC
Bluetooth Name	BT04-E (customizable)
Pairing code	1234 (SPP agreement is valid)
Serial Port Parameters	9600、 8data bits、 1 stop bit, No check, Noflow control
Service UUID	FFE0
Notify UUID	FFE1
Write UUID	FFE2
Storage temperature	MIN:-40°C - MAX:+125°C
Work temperature	MIN:-20°C - MAX:+85°C
Customized requirements	If you have other special function requirements, you can contact us to customize the module.

3. Application area:

The module is mainly used in the field of short-range wireless data transmission. It can be easily connected to the Bluetooth devices of mobile phones and PCs, avoiding the cumbersome cable connection, and can directly replace the serial cable.

- ※ **Bluetooth wireless data transmission**
- ※ **Industrial remote control, telemetry**
- ※ **POS system**
- ※ **Traffic, alarm**
- ※ **Automated data acquisition system**
- ※ **Wireless data transmission; banking system**
- ※ **Wireless data collection**
- ※ **Building automation, security, computer room equipment wireless monitoring, access control system;**
- ※ **Smart home, industrial control;**
- ※ **Medical instruments**
- ※ **Electronic scale**
- ※ **Bluetooth printer, meow machine**
- ※ **Bluetooth remote control toys**
- ※ **Automotive testing equipment**
- ※ **Car diagnostic system OBDII**

4、 Power consumption parameters :

DC-DC	Average Current	Unit
Discoverable	4	mA
Connected(BLE)	4	mA
Connected(SPP)	9	mA

5、 RF characteristics

Rating	Value	Unit
Basic Rate Transmit power	0	dBm
Basic Rate Sensitivity	-90	dBm
BLE Transmit power	0	dBm
BLE Sensitivity	-93	dBm

6、 ransparent transmission parameters**BT04-E dual-mode SPP data throughput :**

Android ->BT04-E -> UART	UART ->BT04-E -> Android	BAUD
12000 bytes/s	4500 bytes/s	115200

BT04-E dual-mode BLE data throughput :

IPhone ->BT04-E -> UART		UART ->BT04-E -> IPhone	
Baud rate	115200	Baud rate	115200
Connection interval(ms)	115200	Connection interval(ms)	15
APP packet size(bytes)	15	Serial packet size (bytes)	80
Send interval(ms)	80	Send interval(ms)	70
Throughput(bytes/s)	50	Throughput(bytes/s)	2500
Characteristic Write	Write without Response	Characteristic Write	Notify

7、Module pin description and minimum circuit diagram

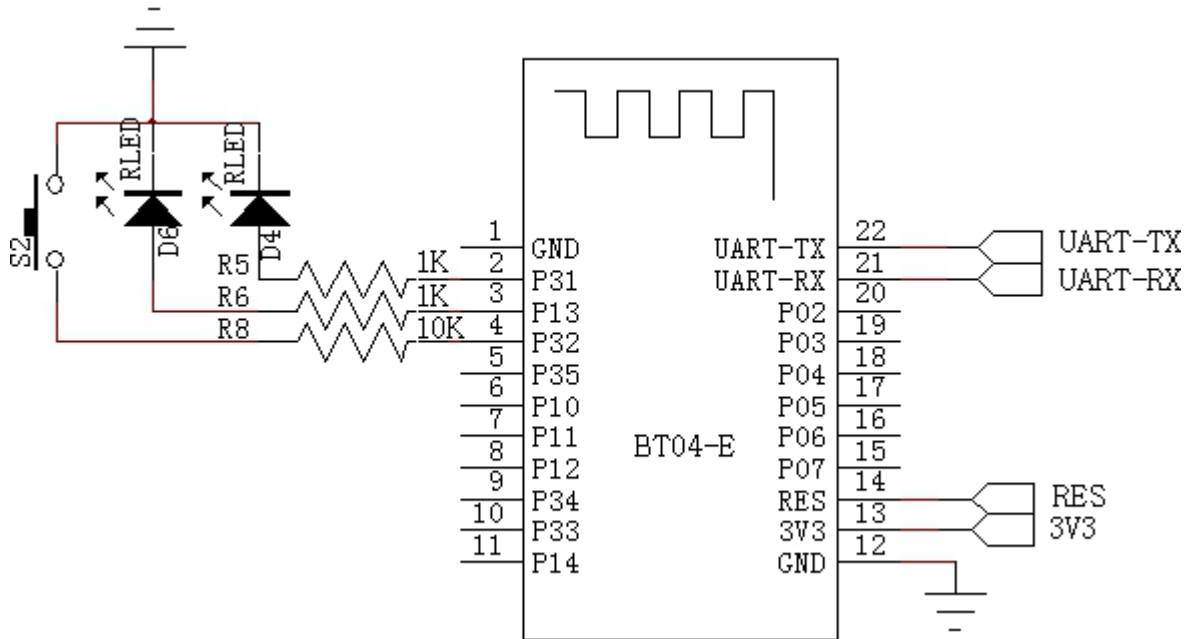

注意：该应用电路图为蓝牙串口电路，如需要其他应用方案，请联系我们

8、Pin function description:

PIN	Name	Type	Function
1	GND	Land	Land
2	P31	output	Module disconnect indication port (see other Set up)
3	P13	output	Connection status indicator LED port (see other Set up)
4	KEY	Bidirectional	Disconnectable (200ms low pulse disconnect)
5	P35	Bidirectional	Programmable input and output port
6	P10	Bidirectional	Programmable input and output port
7	P11	Bidirectional	Programmable input and output port
8	P12	Bidirectional	Programmable input and output port
9	P34	Bidirectional	Programmable input and output port
10	P33	Bidirectional	Programmable input and output port
11	P14	Bidirectional	Programmable input and output port
12	GND	Land	Land
13	3.3V	power input	+3.3V power supply
14	RESET	CMOS input	Reset/Restart Key (Low level reset at least 200ms)

BLM-BT04-E

15	P07	Bidirectional	Programmable input and output port
16	P06	Bidirectional	Programmable input and output port
17	P05	Bidirectional	Programmable input and output port
18	P04	Bidirectional	Programmable input and output port
19	P03	Bidirectional	Programmable input and output port
20	P02	Bidirectional	Programmable input and output port
21	UART-RX	CMOS input	Serial port data input
22	UART-TX	CMOS output	Serial port data output

9、 Other configuration

Status indicator LED: P13

It is used to indicate the status of the Bluetooth module. The flashing mode of the LED light corresponds to the status of the Bluetooth module. See the table below:

mode	LED display	Module status
Standby	Flashes slowly and evenly(500ms-on,500ms-off)	Waitingforpairing
	Long bright	establish connection

Bluetooth module disconnect indication: P31

Used to indicate whether the Bluetooth module is connected, the connection status is high, and the other status is low.

10、 Dimensions:

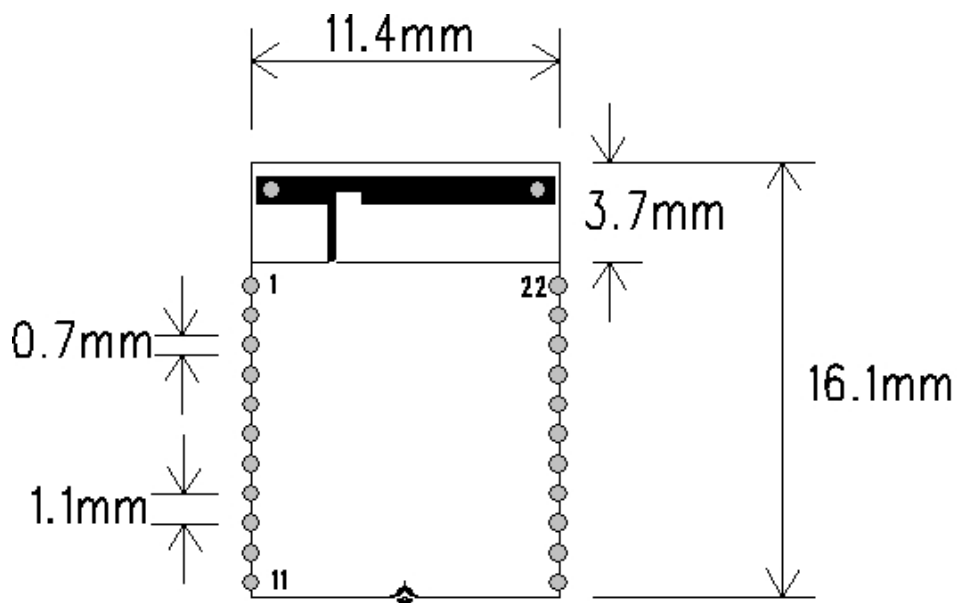

11、 LAYOUT considerations

1. The serial port level of the BLM-BT04-E Bluetooth module needs to be 3.3V. If it is

BLM-BT04-E

connected to a 5V level system, a level conversion chip needs to be added.

2. The Bluetooth signal is greatly affected by the surroundings. Obstacles such as trees, metals, walls, etc. will absorb or shield the Bluetooth signal to a certain extent, so it is recommended not to install it in a metal enclosure.
3. Since metal will weaken the antenna function, it is recommended not to lay the ground and wiring under the module antenna when giving the module Lay board, it is best to be hollowed out.

(Recommend)

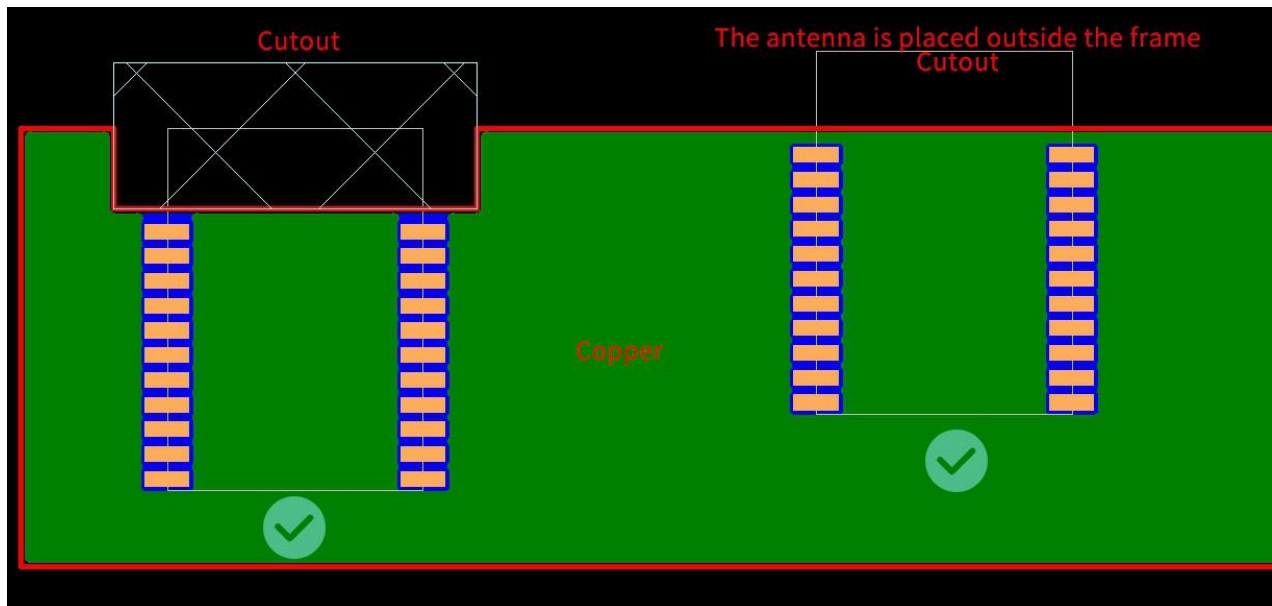

(Not recommend)

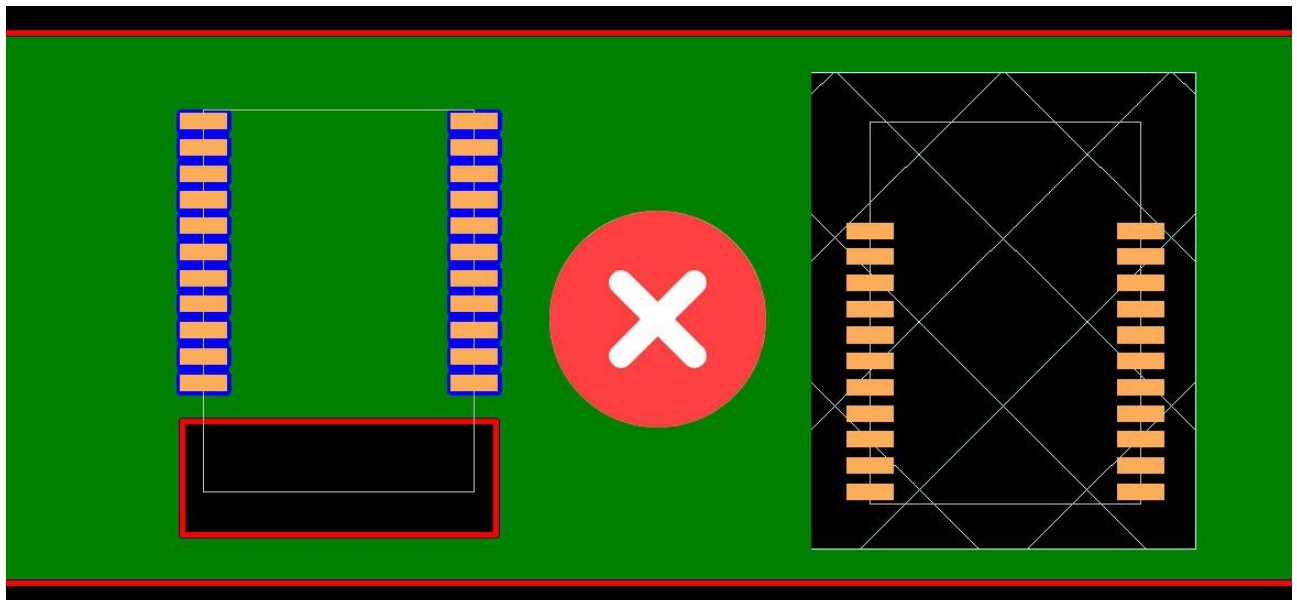

12、 AT COMMAND

BLM-BT04-E

Users can communicate with the BLM-BT04-E Bluetooth module through the serial port. The serial port uses Tx and Rx signal lines

Baud rate support 2400, 4800, 9600, 19200, 38400, 57600, 115200bps

Serial port default baud rate 9600bps

Detailed instruction set description (**AT mode when the module is not connected, and transparent transmission mode when connected**)

BLM-BT04-E Bluetooth serial port module command is Command command set.

(Note: When the module is powered on, if it is not paired, it is in AT mode. AT commands can only take effect when the module is not connected. Once the Bluetooth module is connected to the device, the Bluetooth module enters data transparent transmission mode.)

AT command format example (Figure 1 is AT test command, Figure 2 is to change the Bluetooth name to 1234):

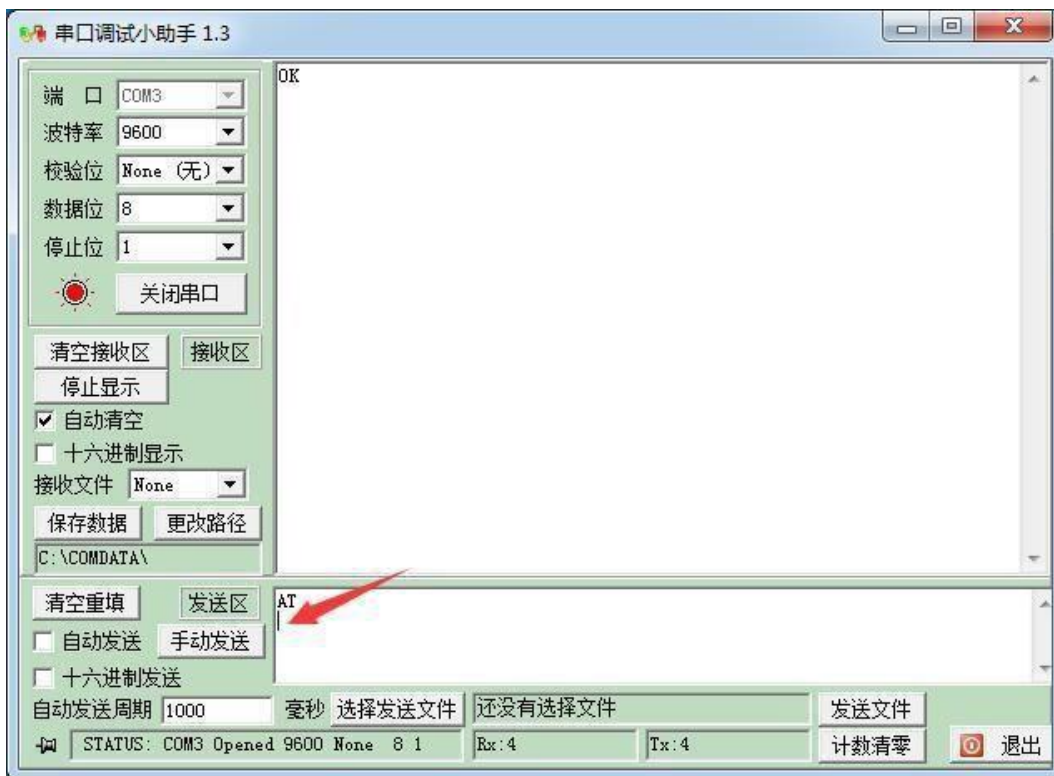

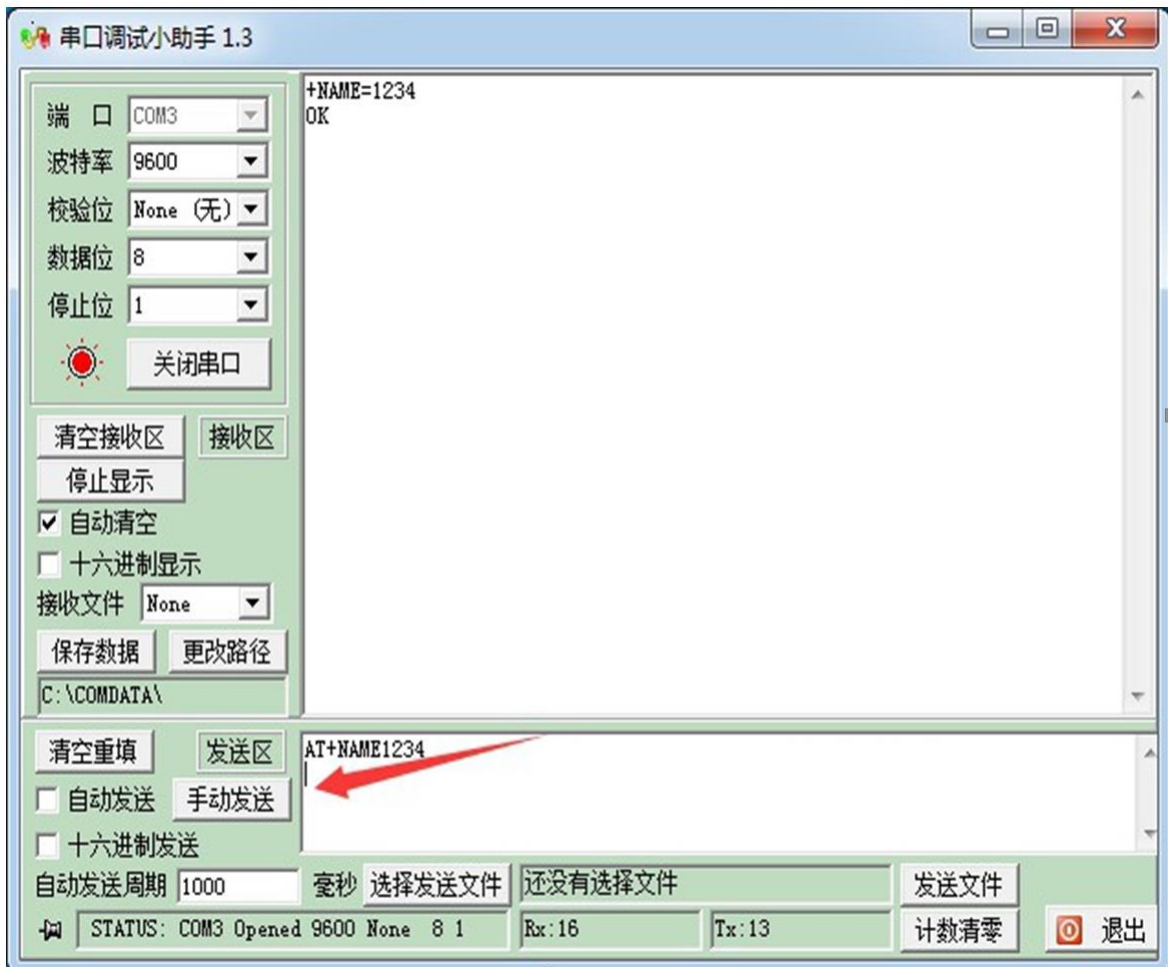

12.1 、 Test Command:

Down command	response	parameter
AT	OK	no

12.2 、 Software restart:

Down command	response	parameter
AT+RESET	OK	No

12.3 、 Get The Software Version:

Down command	response	parameter
AT+VERSION	+VERSION=<Param> OK	Param: Software version number

Example: Send:

AT+VERSION\r\n

Return: +VERSION=2.0-20100601 OK

12.4 、 Restore default settings:

Down command	response	parameter
AT+DEFAULT	OK	No

12.5 、 Query Module Bluetooth MAC:

Down command	response	parameter
AT+LADDR	+ LADDR =<Param>	Param: address code

Example: Send:

AT+LADDR\r\n

Return: +LADDR=11:22:33:44:55:66

11:22:33:44:55:66 is the actual address code obtained from the query.

12.6、 Set/Query Device Name:

Down command	response	parameter
AT+NAME<Param>	OK	Param: Bluetooth device name default name: “BT04-E”
AT+NAME	1、 +NAME=<Param> OK——success 2、 FAIL——failure	

Example: Modify the name of the Bluetooth device1234 Send:

AT+NAME1234\r\n

Return: +NAME=1234

At this time, the Bluetooth name is changed to1234

Parameters can be saved after power-off.

12.7 、 Set/Query-Pairing password:

Down command	response	parameter
AT+PIN<Param>	OK	Param: Default name of the pairing code: “1234”
AT+ PIN	+ PIN =<Param> OK	

Example: Modify the

pairing code to 8888 Send:

AT+PIN8888\r\n Return :

+PIN=8888

At this time, the Bluetooth pairing password is changed to 8888, and the module's default pairing password is 1234.

12.8 、 Set/Query - Serial Port Baud Rate:

Down command	response	parameter
AT+BAUD<Param>	OK	<Param>: Baudrate 2---2400 3---4800 4---9600
	+BAUD=<Param> OK	

BLM-BT04-E

AT+BAUD		5---19200 6---38400 7---57600 8---115200
		default: 4---9600

Example: Modify the baud rate to 38400 Send:

AT+BAUD6

Return: +BAUD=6

At this time the baud rate is 38400

Note: After the baud rate is changed, if it is not the default 9600, the parameter setting or data communication is required to use the set baud rate

12.9、Settings\Query-SERVICE UUID default: FFE0

Down command	response	parameter
(Inquire) AT+UUID	+UUID=<Param>	Param: UUID号
(Set up) AT+UUID<Param>	+ UUID =<Param> OK	

Example: modify/ Inquire SERVICE

UUID Send: AT+UUID\r\n

Return: +UUID=FFE0

Send: AT+UUIDFFE1\r\n

Return: +UUID=FFE1\r\n OK

Note: After the UUID is set, the setting will take effect after a reset operation.

12.10、Inquire/Set up— NOTIFY UUID\ READ UUID default: FFE1

Down command	response	parameter
(Inquire) AT+CHAR	+CHAR=<Param>	Param: UUID号
(Set up) AT+CHAR<Param>	+ CHAR =<Param> OK	

Example: modify/Inquire NOTIFY UUID\ READ UUID

Send: AT+CHAR\r\n

Return: +CHAR=FFE0

Send: AT+CHARFFE1\r\n

Return: +CHAR=FFE1\r\n

OK

Note: After the UUID is set, the setting will take effect after a reset operation.

12.11、Inquire/Set up— WRITE UUID default: FFE2

Down command	response	parameter
(Inquire) AT+WRITE	+WRITE=<Param>	Param: UUID号
(Set up) AT+WRITE<Param>	+ WRITE =<Param> OK	

Example: Modify / Query write to WRITE UUID

Send: AT+WRITE\r\n

Return:+WRITE=FFE2

Send: AT+WRITEFFE1\r\n

Return: +WRITE=FFE1\r\n

OK

Note: After the UUID is set, the setting will take effect after a reset operation.

12.12、 Inquire/Set up—Broadcast time interval

default: 0

Down command	response	parameter
(Inquire) AT+ADVI\r\n (Set up) AT+ADVI<Param>\r\n Example: modify / query broadcast interval Send: AT+ADVI\r\n	+ADVI=<Param>	Param: Broadcast interval 0—100ms 1—152.5ms 2—211.25ms 3—318.75ms 4—417.5ms 5—546.25ms 6—760ms 7—852.5ms 8—1022.5ms 9—1285ms A—2000ms B—3000ms C—4000ms D—5000ms E—6000ms F—7000ms default setting: 0

Return:+AVDI=0

Send: AT+AVID1\r\n

Return:+AVDI=1 OK

(Corresponds to 152.5ms)

Note: After the broadcast interval is set, it needs to be reset to take effect.

13、 Contact us

BLM World Limited

Email: info@blmworld.com

Tel/Whatsapp: +86 13480952801

Website: www.blmworld.com